

### Product summary:

The flow rate sensor is based on the measurement of the pressure difference across an integrated restriction. The module consists of a MEMS sensor with its dedicated electronic signal processing unit.

The Sensor device consists of the fluidic restriction, upstream and downstream independent pressure transducers and a fluid temperature probe. The module provides amplified analog output signals.

Inherently, the sensors provides a fast response time of 1 ms. It thus allows to measure accurately pulsed flow, or when integrated over time, the volume of liquid passing through the sensor.

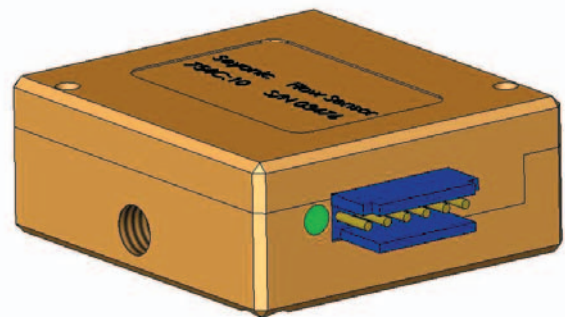

### Features:

- Full Scale Flow range:
  - $\pm 5 \mu\text{L/s}$
  - $\pm 15 \mu\text{L/s}$
  - $\pm 60 \mu\text{L/s}$

for water

### Applications

- **Laboratory instrumentation**
- **Flow controller**
- **Medical instruments**
- **Analytical instruments**
- **Liquid handling**

- Low pressure drop, typ. 250 mbar at Full Scale flow rate.
- Response time 1 ms
- High accuracy, better than 2%FS
- Temperature compensated
- Analog 0-5V outputs
- 8-12 V power supply
- Small size
- Low dead volume,  $< 20 \mu\text{L}$

## Measurement Principle:

The flow rate sensor is based on measurement of the pressure difference across an integrated restriction. The MEMS chip comprises two piezoresistive pressure sensors and a temperature probe. The signals are processed in the module to calculate and correct for the fluid viscosity and temperature effects. The viscosity of the fluid used for the calibration, and its temperature dependence is stored into the micro-controller for the compensation

output signals are available in analog form on the 6 pin connector. They are amplified to fit the output range of the DACs (0-5V).

## Performances:

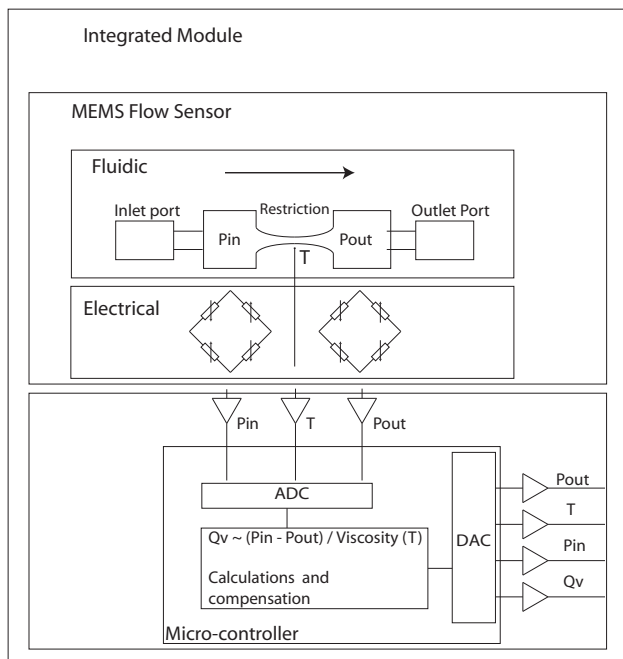

Figure 1. Block Diagram

calculation. By design, the sensor is fully symmetrical, so the output signal is positive with respect to the zero flow output when the flow is in the direction of the arrow. The

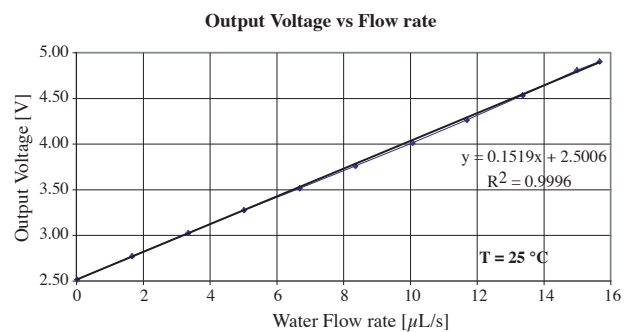

Figure 2. Flow Rate Output

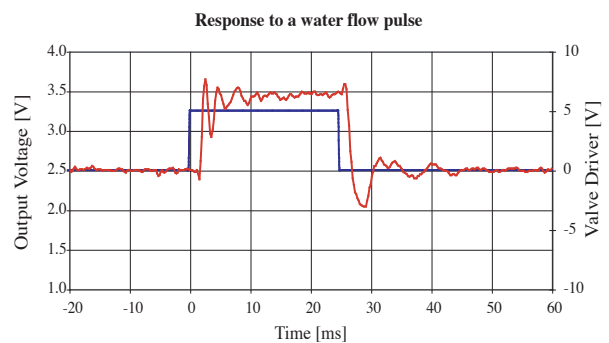

Figure 3. Response time

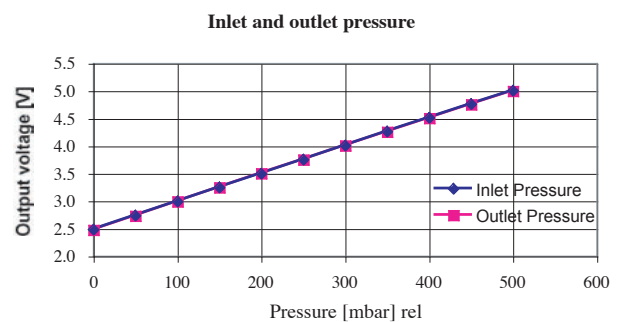
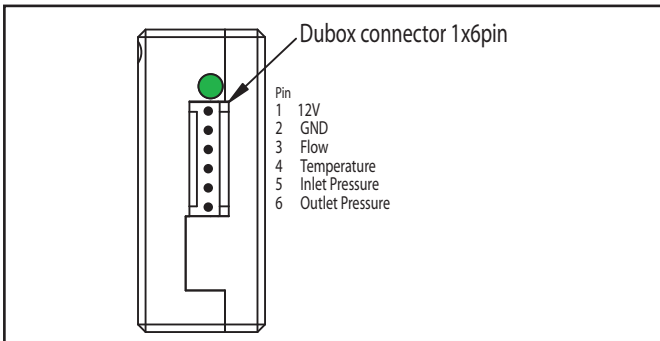

Figure 4. Pressure output signals

## Pinout:



<b>Pressure Range</b>	-500 to +500	mbar rel	other on request
Pressure output	0 to 5	V	inlet and outlet
Zero Pressure output	2.5	V	inlet and outlet
Accuracy	< 1	% FS	per calibration
Temperature range	10-45	°C	per calibration

## Electrical Parameters:

Supply Voltage	8 to 12	V	
Supply Current	100	mA	typical
Output Load	10	mA	max

<b>Temperature Range</b>	10 to 45	°C	other on request
Temperature-output	0 to 5	V	
Temperature output at 25 °C	2.5	V	
Accuracy	< 1	°C	per calibration

## Absolute Maximum Ratings:

Max. Pressure at either port: 3 Bar rel

## Operation:

<b>Flow Range</b>	-5 to 5	$\mu\text{L/s}$	water
	-15 to 15	$\mu\text{L/s}$	water
	-60 to 60	$\mu\text{L/s}$	water
			other ranges on request
Flow Output	0 to 5	V	
Zero Flow output	2.5	V	
Accuracy	2	% FS	per calibration
Response time	< 1	ms	
Pressure drop at Full scale	< 250	mbar	typical, based on water
Temperature range	10-45	°C	per calibration

## Wetted material:

The Flow sensor module has the following material in contact with the fluid:

- Ceramic ( $\text{Al}_2\text{O}_3$ )
- Silicone sealant
- Glass
- Silicon

Housing: Erta PEEK<sup>®</sup>

## Fluidic Ports:

- 1/4-28 compression fittings
- Other fittings on request

## Mechanical drawing:

