

# Air Driven OEM Single Channel Pipettor

Model PCNC-0061-00

## Seyonic Pipetting Technology :

Seyonic's Sensor Controlled Pipetting technology allows very precise monitoring of the liquid handling process. It thus provides not only accurate volume control but also detects pipetting errors in real time. Therefore every pipetting operation can effectively be validated as it is going on. The Process Control Diagnostics allow detection of partial or complete air aspiration while calculating the actually aspirated sample volume. In case of tip clogging, operation is halted immediately to permit the best possibility for recovery.

Process Control Diagnostics are based on analysis of changes in pipetting flow. It is therefore largely independent of the volume or pipetting speed and does not need to establish guide band reference curves for every possible specific pipetting operation.



## Features :

- Wide dynamic range: 0.5  $\mu$ L to 10 mL
- Reporting and validation for all actions
- High precision
- Individual channel control
- Liquid Level Detection (LLD)
- Tip Clogging Detection
- 9 mm tip spacing capability

## Applications :

- General liquid handling
- Clinical diagnostics

## Product Summary:

The Air-driven OEM Single Channel Pipetting Head with integrated flow sensor is suited for liquid handling in sub-microliter to milliliter volume range.

This product has been designed to fit a wide range of applications where action validation and process surveillance is required. The use of a dedicated MEMS flow sensor at the pipetting site allows complete validation of aspiration and dispense actions in real time, as well as providing clogging detection and other process monitoring information.

The Pipettor operates with a pressure/vacuum source, typically in the range of  $\pm 200$  mbar gauge for aspiration/dispense pressure. The pressure controller further acts as System Controller by providing a single port access from the host computer. Integrated high level coordination between the pressure source and the pipetting unit allows an efficient and rapid integration of the unit onto our customer's automated platforms.

# Air Driven OEM Single Channel Pipettor

Model PCNC-0061-00

## Operating Principle :

Aspiration and dispense of the liquid sample is driven by vacuum and positive pressure.

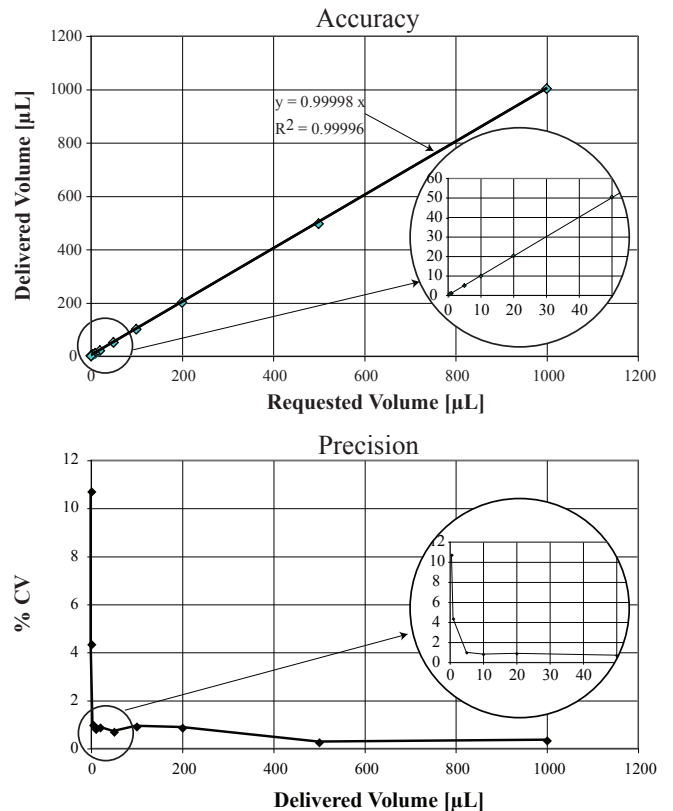
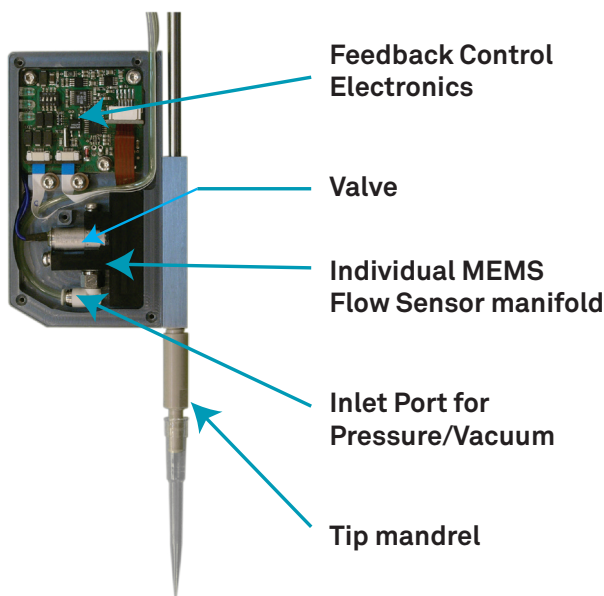

An inlet port provides aspiration/dispense pressure to the channel. A solenoid valve is coupled to a silicon MEMS flow sensor that controls the pipetted volume and allows precise tracking of the operation of the channel.

The Flow sensor and the control electronics provide precise Liquid Level Detection (LLD). The LLD signal can be read via a hardware line. Triggering of pipetting actions can be driven via a hardware line, in addition to being operable via software command on the serial line. A wide range of applications can thus be rapidly implemented.

# Air Driven OEM Single Channel Pipettor

Model PCNC-0061-00

## Specifications :

Operating temperature 10 to 40 °C	Accuracy 1 µL < 10 % 5 µL < 2 % > 20 µL < 1 %	Communication RS 485
Volume range[1] aspirate/dispense 0.5 µL to 10 mL	Typical speed: Aspirate 20 to 1,000 µL/s [3] Dispense 20 to 1,800µL/s [3]	Communication speed up to 115,200 Baud
Precision and accuracy data [2] Precision 1 µL < 5 % CV 5 µL < 2 % CV > 20µL < 1 % CV	Power requirements Nominal 6V/80 mA Peak (valve open)6V/200 mA	Weight 80 g
		Accessories Pressure/Vacuum Source PCNC-0071-00 see separate datasheet

[1] Max aspiration volume depends on internal tip volume. [2] Test protocol and conditions available upon request.

[3] Tested with water based solutions

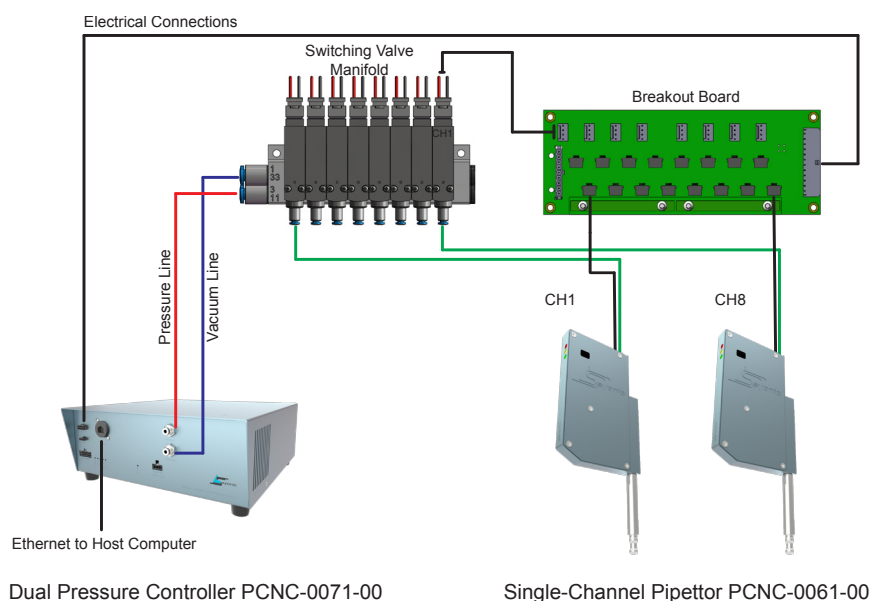

### Product Code

PCNC-0083-10 with  
PCNC-0083-01

### Description

- Starter-kit: 1x Single Channel Pipettor with Pressure Vacuum Controller, 1x switching valve manifold, tubing and cables
- User manual, protocol and command set description
- Compiled stand-alone User Interface Software and Software API for User Application Development

# Air Driven OEM Single Channel Pipettor

Model PCNC-0061-00

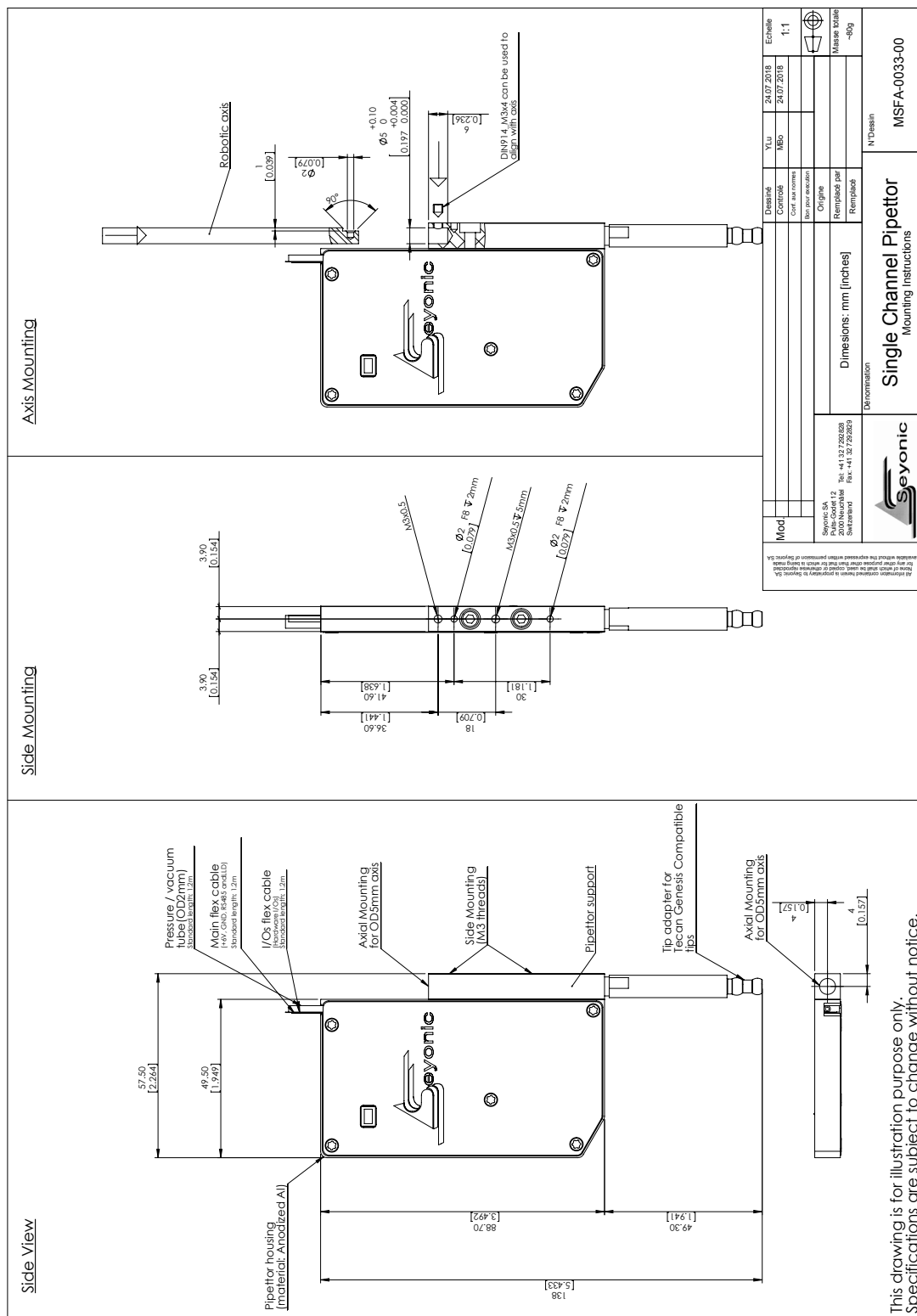

This drawing is for illustration purpose only. Specifications are subject to change without notice.

Mechanical Drawing